

User Manual

Headway

Targeting Module for UAVs,
Ocean Gliders, Robots and Buoys

Table of Contents

PRODUCT OVERVIEW	3
HEADWAY SYSTEM OVERVIEW	4
HEADWAY SPECIFICATIONS	5
PERFORMANCE CHARACTERISTICS	5
ELECTRICAL CHARACTERISTICS.....	5
INTERFACE	7
OPERATION	8
RUN MODE	8
HEADWAY BOARD SUPPORTED VIRTUAL SENSORS	12
VIRTUAL SENSOR AND META EVENT INFORMATION	13
MAGNETIC AUTOMATIC CALIBRATION	19
MECHANICAL DRAWINGS	21

List of Figures

Figure 1-1: Headway Module Block Diagram	4
Figure 3-1 PNI 14480 USB-serial evaluation Cable	7
Figure 4-1: Mounting Options	11
Figure 5-1:Example of a widely distributed autocalibration data set	19
Figure 6-1:Headway.....	21

List of Tables

Table 2-1: Performance Characteristics	5
Table 2-2: Absolute Maximum Ratings.....	5
Table 2-3: Operating Conditions.....	5
Table 3-1 Communication Format.....	7
Table 3-2: Headway Module Pin Assignments	7
Table 4-1 Summary of Simple Serial Character Commands	9
Table 4-2 Summary of Supported Virtual Sensors and Meta Events.....	12

PRODUCT OVERVIEW



Headway (PNI Part number 14714)

Introducing Headway, a breakthrough Low SWaP-C AHRS targeting module that delivers in-field, accurate heading to 1°, without any need for in-field manual calibration.

Unlike other Attitude Heading Reference Systems (AHRS) that require in-field, time-consuming hard-iron and soft-iron recalibration, the Headway targeting module constantly delivers accurate heading data in static and dynamic situations without the need for field recalibration. Headway incorporates PNI's RM3100 magnetic sensor, an accelerometer, a gyroscope, and PNI's SENtral-A2 sensor fusion coprocessor which comes super-charged with the latest, military grade sensor fusion Edge AI algorithms.

Headway is ultra compact, uses ultra-low power and is shock and temperature fluctuation resistant. Headway is easy to integrate and is ideal for use in targeting, drones, unmanned vehicles, oceanology, augmented reality, and virtual reality headsets.

The Headway is a printed circuit board enclosed in aluminum housing with a connector for cable interfacing. For quick evaluation and test, a GUI application can be obtained by contacting support@pnisensor.zendesk.com

HEADWAY SYSTEM OVERVIEW

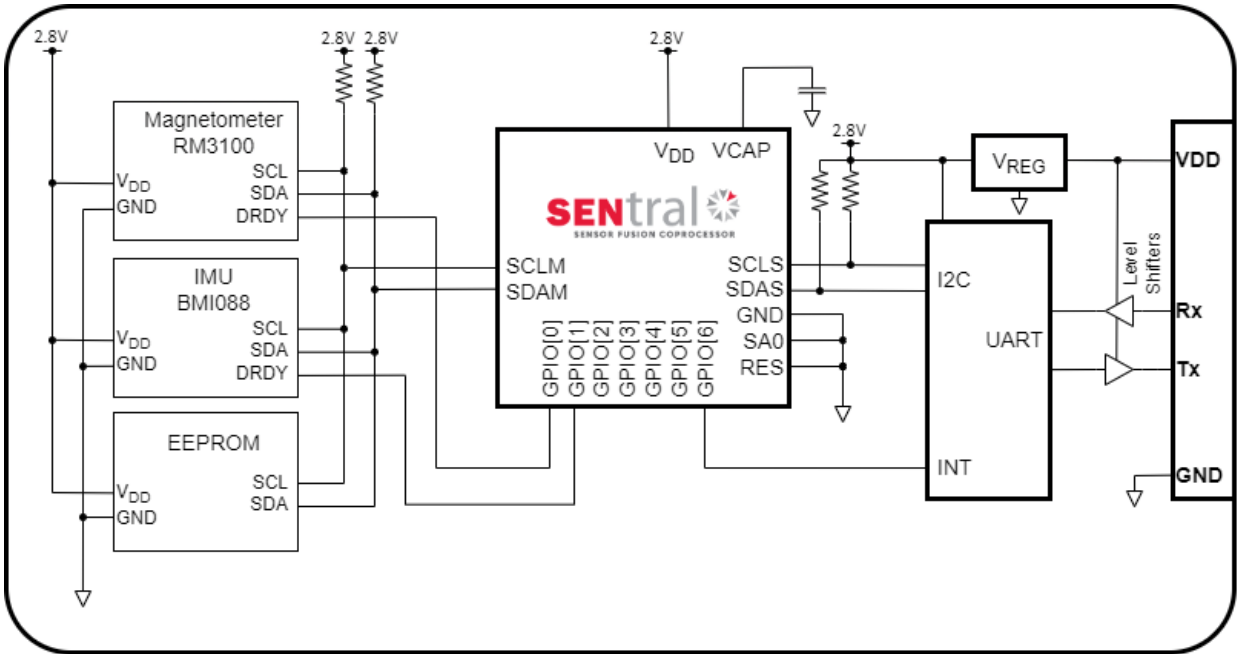

Figure 1-1: Headway Module Block Diagram

The block diagram, above, shows sensors for the Headway. Headway modules incorporate a combination sensor that combines the gyroscope and accelerometer into a single device.

HEADWAY SPECIFICATIONS

PERFORMANCE CHARACTERISTICS

Table 2-1: Performance Characteristics

Parameter	Typical
Heading Accuracy	1° rms
Tilt Accuracy	0.5° rms
Output Data Rate	200 Hz

ELECTRICAL CHARACTERISTICS

Table 2-2: Absolute Maximum Ratings

Parameter	Symbol	Minimum	Maximum	Units
Supply Voltage	V _{IN}	-0.3	+6	VDC
Storage Temperature	T _{STORE}	-50°	+85°	C

CAUTION:

Stresses beyond those listed above may cause permanent damage to the device. These are stress ratings only. Operation of the device at these or other conditions beyond those indicated in the operational sections of the specifications is not implied.

Table 2-3: Operating Conditions

Parameter	Conditions	Value
V _{IN} Supply Voltage		2.9 to 5.5 VDC ⁽¹⁾
I _{IN} Supply Current	max. sample rate	9.5 mA typical
	Sleep Mode	0.38 mA typical
I _{OH} High-level output current (Tx)	V _{IN} = 3.3 V	-7mA max
	V _{IN} = 5 V	-8mA max
I _{OL} Low-level output current (Tx)	V _{IN} = 3.3 V	7mA max
	V _{IN} = 5 V	8mA max
V _{IH} High-level input voltage (Rx)	V _{IN} = 3 V to 3.3 V	1.39 V min

	$V_{IN} = 3.6\text{ V}$	1.48 V min
	$V_{IN} = 4.5\text{ V to }5\text{ V}$	2.03 V min
	$V_{IN} = 5.5\text{ V}$	2.11 V min
V_{IL} Low-level input voltage (Rx)	$V_{IN} = 3\text{ V to }3.6\text{ V}$	0.65 V Max
	$V_{IN} = 4.5\text{ V to }5.5\text{ V}$	0.8 V Max
V_{OH} High-level output voltage (Tx)	$V_{IN} = 2.9\text{ V to }5.5\text{ V}$ $I_{OH} = -20\mu\text{A}$	$V_{IN} - 0.1\text{V min}$
	$V_{IN} = 3\text{ V}$ $I_{OH} = -3\text{mA}$ $I_{OH} = -5.5\text{mA}$	2.7 V min 2.49 V min ⁽²⁾
	$V_{IN} = 3.3\text{ V}, I_{OH} = -5.5\text{mA}$	2.8 V min
	$V_{IN} = 4.5\text{ V}, I_{OH} = -4\text{mA}$	4.1V min
	$V_{IN} = 4.5\text{ V}, I_{OH} = -8\text{mA}$	3.95V min
	$V_{IN} = 5\text{ V}, I_{OH} = -8\text{mA}$	4.5 V min
V_{OL} Low-level output voltage (Tx)	$V_{IN} = 2.9\text{ V to }5.5\text{ V}$ $I_{OH} = 20\mu\text{A}$	0.1V max
	$V_{IN} = 3\text{ V}, I_{OH} = 3\text{mA}$	0.15 V max
	$V_{IN} = 3\text{ V}, I_{OH} = 3\text{mA}$	0.252 V max
	$V_{IN} = 4.5\text{ V}, I_{OH} = 3\text{mA}$	0.2 V max
	$V_{IN} = 4.5\text{ V}, I_{OH} = 3\text{mA}$	0.35 V max
T_{O} Operating Temperature		
Operating Current	Idle (no Sensors Enabled)	12.4 mA
	Rotation Vector (max ODR)	17.8 mA
	Geo-Mag Rot (min ODR)	12.9 mA
	All Sensors (Max ODR)	20.4 mA

TTL-compliant logic levels guaranteed for $V_{IN} = 3.0\text{V to }5.5\text{V}$ with R_x load $\leq 3\text{mA}$ or $V_{IN} = 3.3\text{V to }5.5\text{V}$ with loads $\leq 8\text{mA}$. CMOS-compliance is guaranteed the entire V_{IN} voltage range.

High load currents at low V_{IN} voltages may prevent device from producing TTL-compliant voltages.

Table 3-1 Communication Format

Parameter	Value
Communication Interface	TTL/CMOS serial UART
Communication Protocol	ASCII
UART Configuration	115200 Baud 8-bit data 1-stop bit No parity bits

The Headway pin-out is given in Table 3-2. See Table 2-3 for the operating voltage range.

Table 3-2: Headway Module Pin Assignments

Pin Name	Description	Pin#
GND	Ground	1
V _{IN}	Supply Voltage	2
TX	UART Transmit Output	3
RX	UART Receive Input	4

Headway UART mating connector is 4-pin Molex PicoBlade, housing part number 0510210400, or pigtail cable assembly part numbers 218112040X, where X = 0 through 3.

A 1.8 Meter USB-Serial cable, shown in Figure 3-1 below, is available from PNI Sensor as part number 14480.

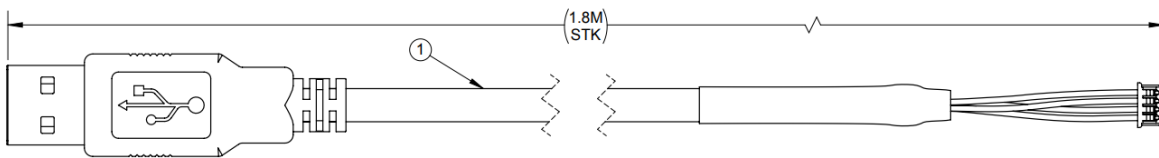

Figure 3-1 PNI 14480 USB-serial evaluation Cable

OPERATION

The Headway has two distinct modes of execution: Boot Mode, Main Execution Mode.

The Boot Mode is transparent to the user and happens automatically upon power-up, after which the module enters Idle state of the Execution Mode.

RUN MODE

A list of the ASCII Serial commands are given in Table 4-1 on the next page. These are the UART commands used by the Headway modules.

Following that table is Table 4-2 which lists the available virtual sensors and meta events with their respective IDs. The IDs are used with the start command to start and stop specific sensors. The IDs are also used in the non-verbose mode of the output data stream to identify the data packets.

Table 4-1 Summary of Simple Serial Character Commands

Note: Commands are CASE Sensitive!

Char	Description
Configuration and Status	
n	Display sensor information
v	Display Version
O	One-Shot Orientation Sensor*
M#[CR]	Mounting Options # is limited to 1-16. See Figure 4-1 for specific mounting options [CR] = carriage return (0x0D).
J3	Set module to NED orientation
J4	Set module to ENU orientation (Default)
Sensor Selection and Rates	
s #,#[CR]	Start Sensor at given rate. where: 1 st # = Sensor ID. See Table 4-2 Summary of Supported Virtual Sensors and Meta Events 2 nd # = Data rate (Aggregate data rate should not exceed 1200 Hz) [CR] = carriage return (0x0D).
Display Controls	
m0	Meta event reporting off
m1	Meta event reporting on
m[CR]	Toggle meta event reporting(on/off) Default (On)
D0	sensor Data display off
D1	sensor Data display on
D[CR]	Toggle sensor Data display (on/off) Default (On)
V0	Verbose Mode off
V1	Verbose Mode on
V[CR]	Toggle Verbose Mode (on/off) Default (On)

Additional Controls	
P	Power Down (Low power mode) - Everything is turned low power (~500 uW) until next UART event to wake up.
S	Save factory calibration parameters
X	Restart system
J1	Stop autocal (this will reset the current autocal values)
J0	Start autocal
A#[CR]	Change Application Mode to number # # = desired application mode 0-5. 0 is custom, higher numbers merge faster. [CR] = carriage return (0x0D). If A0[CR] is selected, custom mode will be entered. In this case 5 knobs will be requested. Enter a number followed by [CR] for each of these knobs. For reference the default A3 setting would have values 1,2,2,1,80.**
A[CR]	Report the current Application Mode
?	Display commands menu
Tests	
B	Run RM3100 Self tests

* The one-shot orientation sensor is a version of sensor 3 (orientation) that happens as a “one-shot” command. This is for the convenience of customers to have a sensor type without additional buffer parsing. Whenever the user inputs the command ‘O’, the orientation sensor will output a single set of values. These values are **timestamp, sensor type (3, or “Orientation” in verbose mode), Azimuth, Pitch, Roll, Calibration Score, Distortion Flag (meta event 5)**. If this command is made without first enabling sensor 3, the system will default to update the one-shot register at 30hz and show no additional Orientation sensor updates to buffer (use D[CR] command to display normal Orientation sensor).

** Setting A0 is custom mode, this allows custom changes to sensor knobs. Summary of knobs:
Time constants (first 3 custom knobs): Recommended values 0.1-100 (float), Lower numbers will merge faster. TC1 controls overall merge rate. TC2 controls mag merge rate. TC3 controls accel merge rate.
Dynamic accel (4th custom knob): Recommended values 1-20 (uint), Higher numbers will reduce accel merging during dynamic motion.

Still Delay (5th custom knob): Recommended values 10-1000 (uint), Higher numbers will result in a longer period of time after unit is set down before merging stops.

Figure 4-1: Mounting Options (M#[CR] command)

Index of each mounting option shown in parenthesis

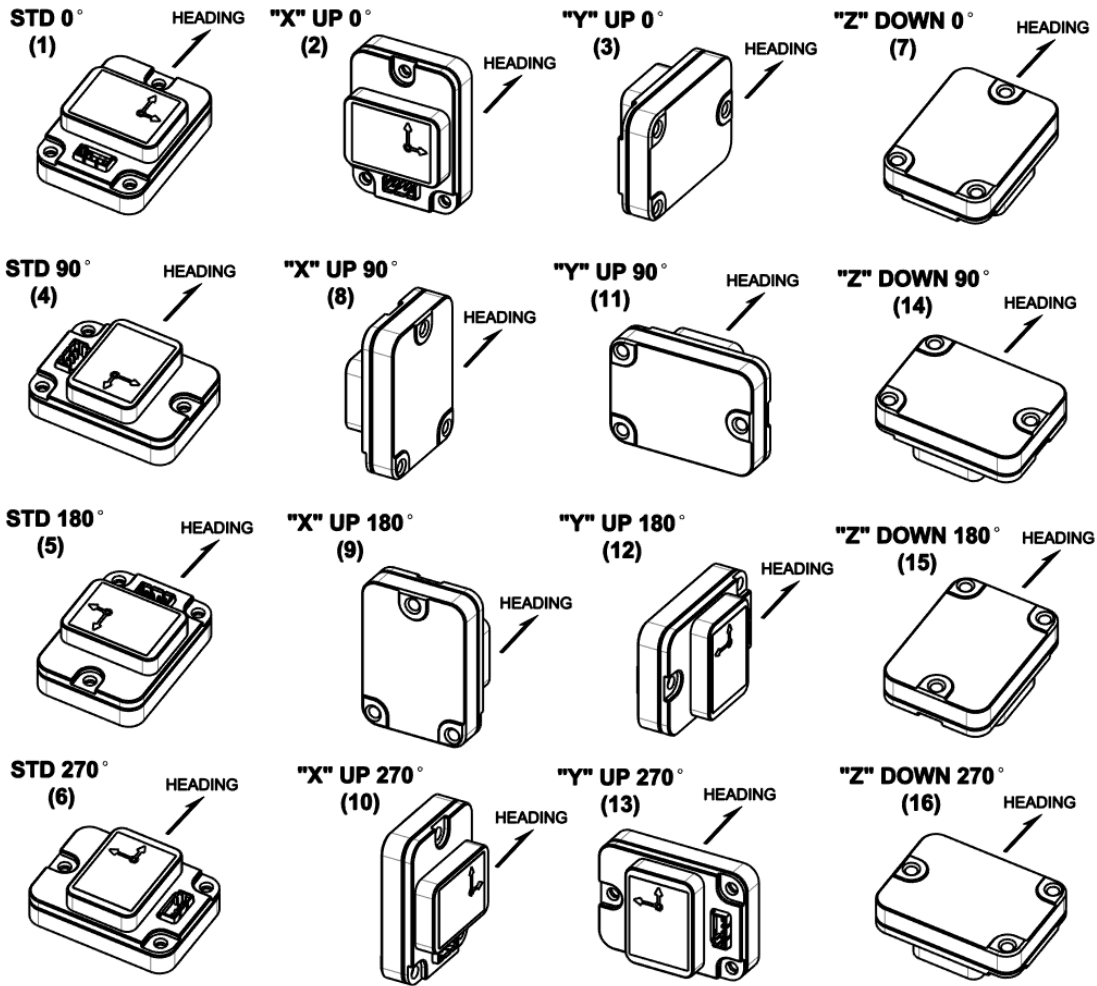

HEADWAY BOARD SUPPORTED VIRTUAL SENSORS

Table 4-2 Summary of Supported Virtual Sensors and Meta Events

Sensor ID	Description	Type
1	Accelerometer (uncalibrated)	Continuous
2	Magnetometer	Continuous
3	Orientation	Continuous
4	Gyroscope (temperature compensated)	Continuous
6	Pressure	Continuous
7	Temperature	Continuous
9	Gravity	Continuous
10	Linear Acceleration	Continuous
11	Rotation Vector (9DOF)	Continuous
14	Magnetometer Uncalibrated	Continuous
15	Game Rotation Vector (6DOF accelerometer + gyroscope)	Continuous
16	Gyroscope Uncalibrated	Continuous
17	Significant Motion	One shot
20	Geomagnetic Rotation Vector (6DOF accelerometer + magnetometer)	Continuous
254	Meta Events Used in HEADWAY	
	4	Error
	5	Magnetic Transient
	6	Cal Status Changed
	7	Stillness Changed
	9	Calibration Stable
	15	Self-Test (BIST) Results

VIRTUAL SENSOR AND META EVENT INFORMATION

Listed below are the interface specifications for the most used Virtual Sensors and Meta Events that occur in the host readable FIFO stream. When the host enables these virtual sensors, the Virtual sensors' output data is posted to the host readable FIFO at prescribed rates.

UART Output Format:

Verbose Mode (Off)

```
Timestamp,SensorID[,Value][,Value]...[,Value] LFCR
```

Verbose Mode (On) -default

```
Timestamp,event name [,Value][,Value]...[,Value] LFCR
```

Example:

Verbose Mode (Off)

```
246511934, 14, -0.020935, 0.006653, -0.690308, 0.723145, -2.496170 LFCR
```

Verbose Mode (On) -default

```
246511934, Rotation Vector, -0.020935, 0.006653, -0.690308, 0.723145, -2.496170 LFCR
```

Notes:

Each line ends with a Linefeed and Carriage return, (^L_F^C_R).

The timestamp is a Uint32 type that will wrap on overflow. The units are uncalibrated picoseconds

The formats of the Sensor payloads are given in the following section

KEY for the following Sensor and Event listings

SENSOR_TYPE ID#:	This is the SENSOR_TYPE ID value written to ParamIO page 3 to select a particular virtual sensor.
Sample_Rate:	A zero sample rate disables the virtual sensor.
Reporting Type:	Wake-up type Virtual sensors will interrupt the host even in AP_Suspend mode Continuous mode will report data to the host continuously at the sample rate ON-Change mode will only report data to the host if the data value(s) have changed.
Payload size:	Number of Comma Separated Values not including the Time Stamp and SENSOR_TYPE ID in each report sentence sent to the host interface FIFO. All payloads end with a Carriage Return [CR], 0X0D.
Payload Values:	The range and type of each data value is listed along with a short description
Description:	Describes the operation of this virtual sensor or event

Accelerometer

SENSOR_TYPE ID#:	1
Sample Rate:	Set by user, 0-400Hz
Reporting Type:	Continuous
Payload size:	4
Payload Values:	X, Y, Z, Accuracy
Description:	Acceleration sensor, no autocalibration performed Values X, Y, and Z units are m/s ²

Magnetometer

SENSOR_TYPE ID#:	2
Sample Rate:	Set by user, 0-125Hz
Reporting Type:	Continuous
Payload size:	4
Payload Values:	X, Y, Z, Accuracy
Description:	Magnetometer sensor, auto-calibration performed X, Y, and Z values are in micro-Tesla (uT)

Orientation

SENSOR_TYPE ID#:	3
Sample Rate:	0-400Hz
Reporting Type:	Continuous
Payload size:	4
Payload Values:	Yaw, Pitch, Roll, Accuracy
Description:	A 9DOF calculation from Accel, Mag and Gyro sensors Values Azimuth (Yaw/Heading), Pitch, and Roll are in degrees Accuracy is the magnetometer autocalibration score, approximately in degrees RMS heading. Autocal score of 180 indicates the system is not yet calibrated.

Gyroscope

SENSOR_TYPE ID#:	4
Sample Rate:	Set by user, 0-400Hz
Reporting Type:	Continuous
Payload size:	4
Payload Values:	X, Y, Z, Accuracy
Description:	Device specific output data from Gyroscope sensor, bias removed X, Y, & Z units are radians per second (rad/s)

Pressure

SENSOR_TYPE ID#: 6
Sample Rate: 0-50Hz
Reporting Type: Continuous
Payload size: 1
Payload Values: Pressure values are in Pascals
Description: Output data from Pressure sensor

Temperature

SENSOR_TYPE ID#: 7
Sample Rate: 0-50Hz
Reporting Type: Continuous
Payload size: 1
Payload Values: Temperature values are in degrees Celsius
Description: Output data from Temperature sensor

Acceleration components (2 types)

SENSOR_TYPE ID#: 9 **Gravity**
 10 **Linear Acceleration**

Sample Rate: 0-400Hz
Reporting Type: Continuous
Payload size: 5
Payload Values: X, Y, Z, Accuracy
Description: Gravity and linear acceleration components of acceleration sensor
Values X, Y, and Z units are m/s²

Quaternions (3 types)

SENSOR_TYPE ID#: 11 **Rotation Vector (9-DOF Accel/Mag/Gyro)**
 15 **Game Rotation (6-DOF Accel/Gyro)**

	20	Geo-magnetic Rotation (6-DOF Mag/Accel)
Sample Rate:	0-400Hz	(Geo-magnetic Rotation maximum rate is 125Hz)
Reporting Type:	Continuous	
Payload size:	5	
Payload Values:	Q _x , Q _y , Q _z , Q _w , Accuracy	
Description:	<p>Quaternion Output data from Rotation Vector Virtual Sensors.</p> <p>A rotation vector sensor reports the orientation of the device relative to the East-North-Up (ENU) coordinates frame. The ENU coordinate system is defined as a direct orthonormal basis where when body is aligned with Earth frame:</p> <p style="padding-left: 40px;">X points east and is tangential to the ground.</p> <p style="padding-left: 40px;">Y points north and is tangential to the ground.</p> <p style="padding-left: 40px;">Z points towards the sky and is perpendicular to the ground.</p>	

Magnetometer Uncalibrated

SENSOR_TYPE ID#:	14	
Sample Rate:	Set by user, 0-125Hz	
Reporting Type:	Continuous	
Payload size:	7	
Payload Values:	X, Y, Z, X offset, Y offset, Z offset, Accuracy	
Description:	<p>Magnetometer sensor, auto-calibration not performed</p> <p>X, Y, and Z values and offsets are in micro-Tesla (uT)</p>	

Gyroscope Uncalibrated

SENSOR_TYPE ID#:	16	
Sample Rate:	Set by user, 0-125Hz	
Reporting Type:	Continuous	
Payload size:	7	
Payload Values:	X, Y, Z, X bias, Y bias, Z bias, Accuracy	
Description:	<p>Device specific output data from Gyroscope sensor, bias not removed</p> <p>X, Y, & Z values and biases are radians per second (rad/s)</p>	

Meta Event

SENSOR_TYPE ID#: 254

Reporting Type: On Change

Payload size: 3

Payload Values			
Value 1 – Meta Event type ID		Value 2	Value 3
4	Error	Error Register	Debug State
5	Magnetic Transient	1 = transient detected 0 = no transient detected	0
6	Cal Status Changed	Cal Status Value	Trans Component
7	Stillness Changed	1 = now still 0 = no longer still	0
9	Calibration Stable	1 = stable 0 = not stable	0
15	Self-Test (BIST) Results	Sensor ID	Test results 0 = pass

MAGNETIC AUTOMATIC CALIBRATION

An important part of the Headway system is the ability to automatically calibrate the magnetometers. This allows the system to adapt to changes in environment, including transient magnetic fields, new hardware changes, and temperature changes. While this calibration is automatic, for the system to perform an accurate calibration, it is still necessary for the sensors to see a wide range of positions. Order does not matter, nor timing, but the wider the range of positions the better the magnetic calibration is likely to perform. Figure 5-1 shows a wide distribution of magnetometer points, showing different points of heading at different pitch angles.

Figure 5-1: Example of a widely distributed autocalibration data set

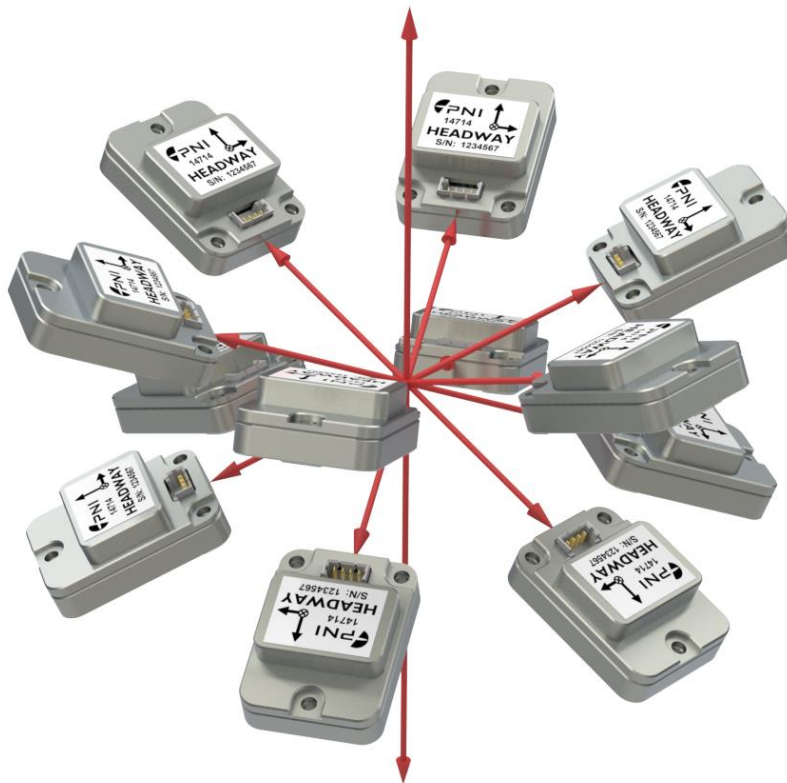

A set of motions similar to an iPhone “figure 8” pattern would also be acceptable, if perhaps slightly less accurate. The mag score (the 4th value in the Orientation sensor) starts at 180 degrees when not calibrated, and will change to a lower value when calibrated. Changes will only be made when the system believes that it universally improves magnetic accuracy. The score may go down during continued motion, indicating that the system is improving accuracy. Calibration score approximately corresponds to RMS heading accuracy; however, this accuracy is entirely self-contained, and therefore is only an approximate value, not an absolute indicator of system accuracy. Scores less than the specified accuracy (1 degree for Headway), should provide acceptable accuracy. If the system is rigidly attached to a magnetic distortion, such as placement in a new system, it will adapt to that system after some movement.

The "**Accuracy**" term located in the Orientation sensor (#3) and One-shot sensor is the most critical term for determining the status of the automatic calibration. "Accuracy" represents the calibration score of the autocalibration system; it approximately corresponds to degrees RMS of error in the system. The degrees RMS is not precisely accurate, as it is a post-fit residual, not an absolute measure of system accuracy. On startup, if no autocalibration has been saved, the "accuracy" term will be 180; this indicates that the system has not yet performed calibration. Once the system has seen enough of the connected system's magnetic field, it will transition to a different calibration score. When the accuracy value changes, this means an automatic calibration has been performed and that the overall system accuracy should now be significantly better. Accuracy values less than 2 are considered very good, though this will not always be possible depending on the latent magnetic field of the system. At this point, if no further physical changes are expected for the system, it is possible to save the automatic calibration command using the "**S**" command; this will keep the current calibration and score and use it on future system startups. If the "**S**" command is used accidentally, or the autocalibration score is no longer desired as is, the "**J1**" and "**J0**" commands can be used to reset it (remember to save any state changes using the "**S**" command). If the magnetics of the system drastically changes, for example if a large battery is attached to the system, the automatic calibration will account for this but might take longer to do so than initial calibration. Automatic calibration is very conservative, so it may take significant motion before making changes; this is to ensure that newly attached magnetic devices are truly attached and not the result of a transient magnetic field.

The "Magnetic Transient" flag is also very useful for observing the behavior of the system. This is meta event #5, as well as a field in the "One-shot sensor". When transient is 0, the device is observing a clean field, and is actively merging to the magnetic field (using the compass). When transient is 1, the system is assumed to be in a transient magnetic field and the magnetometer is not being used. Higher transient values indicate the system has been in a transient field for a prolonged period. Once a value of 3 is reached the system will begin merging to the magnetometer once again; additional movement is recommended to either calibrate to the current field or leave the vicinity of the magnetic transient. High transient values could also indicate that a magnetic anomaly attached to the unit is not rigid, i.e. if a piece of iron is bouncing or rotating, this could cause a prolonged transient.

Figure 6-1: Headway

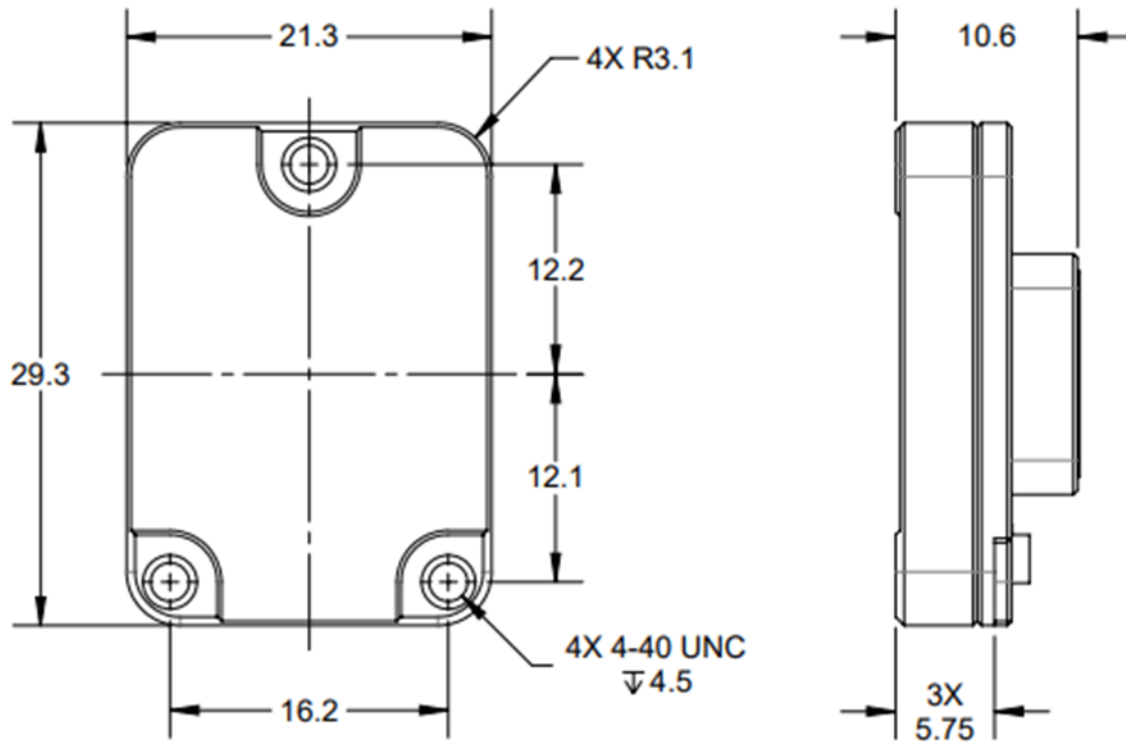

©2023 PNI Sensor. All Rights Reserved.

Reproduction, adaptation, or translation without prior written permission is prohibited, except as allowed under copyright laws.

Revised March 2016: for the most recent version of this document visit our website at www.pnicorp.com

PNI Sensor
2331 Circadian Way
Santa Rosa, CA 95407, USA
Tel: (707) 566-2260
Fax: (707) 566-2261

Warranty and Limitation of Liability. PNI Sensor ("PNI") manufactures its Products from parts and components that are new or equivalent to new in performance. PNI warrants that each Product to be delivered hereunder, if properly used, will, for ninety (90) days following the date of shipment unless a different warranty time period for such Product is specified: (i) in PNI's Price List in effect at time of order acceptance; or (ii) on PNI's web site (www.pnicorp.com) at time of order acceptance, be free from defects in material and workmanship and will operate in accordance with PNI's published specifications and documentation for the Product in effect at time of order. PNI will make no changes to the specifications or manufacturing processes that affect form, fit, or function of the Product without written notice to the Customer, however, PNI may at any time, without such notice, make minor changes to specifications or manufacturing processes that do not affect the form, fit, or function of the Product. This warranty will be void if the Products' serial number, or other identification marks have been defaced, damaged, or removed. This warranty does not cover wear and tear due to normal use, or damage to the Product as the result of improper usage, neglect of care, alteration, accident, or unauthorized repair.

THE ABOVE WARRANTY IS IN LIEU OF ANY OTHER WARRANTY, WHETHER EXPRESS, IMPLIED, OR STATUTORY, INCLUDING, BUT NOT LIMITED TO, ANY WARRANTY OF MERCHANTABILITY, FITNESS FOR ANY PARTICULAR PURPOSE, OR ANY WARRANTY OTHERWISE ARISING OUT OF ANY PROPOSAL, SPECIFICATION, OR SAMPLE. PNI NEITHER ASSUMES NOR AUTHORIZES ANY PERSON TO ASSUME FOR IT ANY OTHER LIABILITY.

If any Product furnished hereunder fails to conform to the above warranty, Customer's sole and exclusive remedy and PNI's sole and exclusive liability will be, at PNI's option, to repair, replace, or credit Customer's account with an amount equal to the price paid for any such Product which fails during the applicable warranty period provided that (i) Customer promptly notifies PNI in writing that such Product is defective and furnishes an explanation of the deficiency; (ii) such Product is returned to PNI's service facility at Customer's risk and expense; and (iii) PNI is satisfied that claimed deficiencies exist and were not caused by accident, misuse, neglect, alteration, repair, improper installation, or improper testing. If a Product is defective, transportation charges for the return of the Product to Customer within the United States and Canada will be paid by PNI. For all other locations, the warranty excludes all costs of shipping, customs clearance, and other related charges. PNI will have a reasonable time to make repairs or to replace the Product or to credit Customer's account. PNI warrants any such repaired or replacement Product to be free from defects in material and workmanship on the same terms as the Product originally purchased.

Except for the breach of warranty remedies set forth herein, or for personal injury, PNI shall have no liability for any indirect or speculative damages (including, but not limited to, consequential, incidental, punitive and special damages) relating to the use of or inability to use this Product, whether arising out of contract, negligence, tort, or under any warranty theory, or for infringement of any other party's intellectual property rights, irrespective of whether PNI had advance notice of the possibility of any such damages, including, but not limited to, loss of use, revenue or profit. In no event shall PNI's total liability for all claims regarding a Product exceed the price paid for the Product. PNI neither assumes nor authorizes any person to assume for it any other liabilities.

Some states and provinces do not allow limitations on how long an implied warranty lasts or the exclusion or limitation of incidental or consequential damages, so the above limitations or exclusions may not apply to you. This warranty gives you specific legal rights and you may have other rights that vary by state or province.

Revision Control Block

<u>Revision</u>	<u>Description of Change</u>	<u>Effective Date</u>	<u>Approval</u>
V1.0	Released	01/04/2023	HN
V1.1	Added Mag Transient, Cal status, and Cal score information. Also fixed general typos	02/28/2023	HN
V1.2	Fixes related to new one shot, knobs, and other new features	03/14/2023	JT
V1.3	Updates to clarify user calibration	4/19/2023	JT